



AMERICAN EAGLE[®]
FOOD MACHINERY, INC.

**AE-DS650ZD-SS/
 AE-650B/AE-520B-SS**
**Premium Series Stainless
 Steel Floor Type Sheeters**

773.376.0800 (P) • 773.376.2010 (F) • 3131 S. Canal St. Chicago, IL 60616

**AE-DS650B-SS
 Shown**



Fully Automated Model Available!

Premium 100% Stainless Steel Build
**Inverter Technology Powers Reliable
 3-Phase Motor From Common
 220V/1-Phase Electricity**

Quality Design

- Powerful 1.5HP 3-Phase Motor With Power Inverter Technology
- Quiet and Durable Belt Transmission and Chain Driven Conveyor Rollers
- Easy-to-Remove Scrapers and Removable Working Tables for Ease of Cleaning, Storage and Conveyor Belt Replacement
- Reversible Belts With Sync Drive (Output Conveyor Faster Than Input)
- Ergonomic One-Handed Conveyor Controls and Hands-Free Foot Pedals
- Dual Pin Locking Handle Rail and Digital Readout For Precise Pressing Roller Height Adjustment

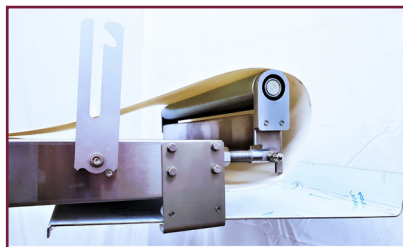

**Easy To Remove
 Scrapers For
 Daily Cleaning!**

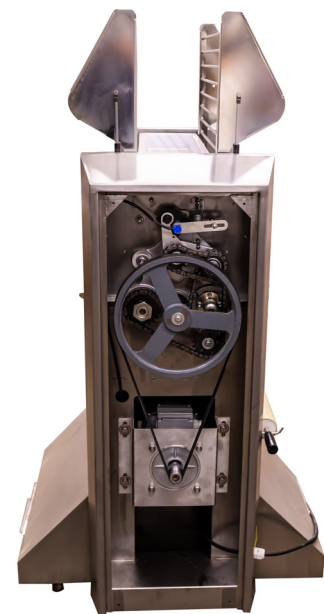

**Pop-Up Conveyor Rollers, Large
 Access Panels, and Removable
 Working Tables Allow Easy
 Cleaning and Maintenance**

Standard Features

- OSHA Compliant Soft-Close (Gas-Strut Mounted) Safety Guard Auto-Shutoffs When Opened
- Time-Saving Dough Transfer Roller
- Emergency Stop and Power Override
- Dual Retractable Dough Trays On Each Side
- Heavy Duty 6 ft 3-Wire Power Cord
- 1 Year Limited Warranty

**Fully Automated
 Model Has
 Programmable
 Recipes, Sensor
 Controlled Rollers
 and Flour Release**



Proud Member of:

 North American Association of
 Food Equipment Manufacturers

Quality • Value • Reliability



AMERICAN EAGLE[®]
FOOD MACHINERY, INC.

**AE-DS650ZD-SS/
 AE-650B/AE-520B-SS**
**Premium Series Stainless
 Steel Floor Type Sheeters**

sales@ameagle.biz • www.americaneaglemachine.com

Our Premium Series Stainless Steel Dough Sheeters Help Achieve Consistent Results While Saving Time, Labor, and Training Costs! Easy To Use Manual Models or Fully Automatic Programmable Model Available.

Specifications

Model	Working Mode	Motor	Input Power V/HZ/PH	Pressing Roller Size	Adjustable Thickness	Roller Control	Foot Pedal	Max Dough Batch**	Working Surface
AE-DS520B-SS	Manual	1.5 HP	220/60/1	3.5" Dia x 20" L (9cm x 50.5cm)	.00" to 1.96" 0mm-50mm	Locking Rail	Yes	12 lbs	19.75" x 82" 50cm x 208cm
AE-DS650B-SS	Manual	1.5 HP	220/60/1	3.5" Dia x 25.75" L (9cm x 65.5cm)	.00" to 1.96" 0mm-50mm	Locking Rail	Yes	15 lbs	25.6" x 110" 65cm x 279cm
AE-DS650ZD-SS	Full Auto	1.5 HP	220/60/1	3.5" Dia x 25.75" L (9cm x 65.5cm)	.00" to 1.96" 0mm-50mm	Motorized	No	18 lbs	25.6" x 144.5" 65cm x 367cm

Measurements

Dimension	AE-DS520B-SS		AE-DS650B-SS		AE-DS650ZD-SS	
A	82.5 in	210 cm	110.5 in	281 cm	148 in	376 cm
B	49 in	125 cm	49 in	125 cm	59 in	150 cm
C	67 in	170 cm	70 in	178 cm	63 in	160 cm
D	33.5 in	85 cm	40 in	102 cm	44 in	112 cm
E	34 in	86 cm	36 in	91 cm	34 in	86 cm

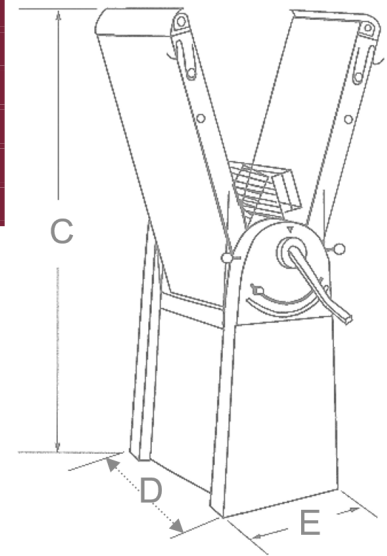
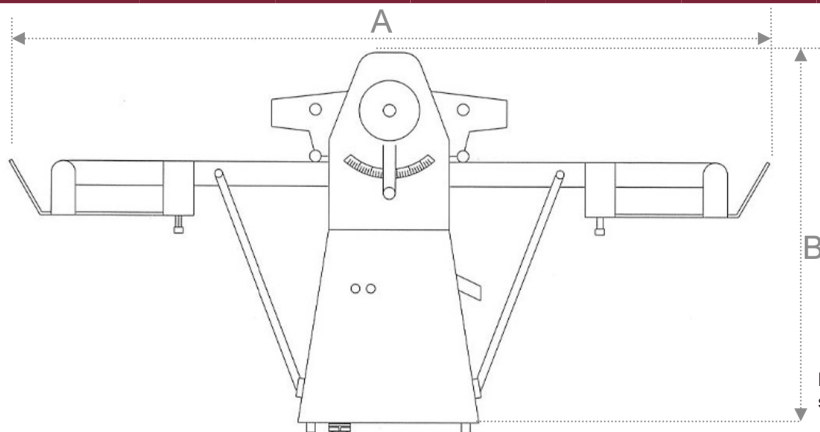

Line drawings are for reference only. Current safety guard, switches, or controls may vary in design or cosmetic appearance

Dimensions and Shipping Information

Model	Overall Dimensions***	Shipping Dimensions****	Net Weight	Ship Weight	Freight Class
AE-DS520B-SS	83" L x 38" W x 50" H	55" L x 42" W x 59" H	705 lbs (320 kg)	816 lbs (370 kg)	85
AE-DS650B-SS	111" L x 44.5" W x 50" H	60" L x 42" W x 65" H	772 lbs (350 kg)	893 lbs (405 kg)	85
AE-DS650ZD-SS	149" L x 45" W x 60" H	#1: 55"L x 42" W x 70" H #2: 85" L x 34" W x 24" H	816 lbs (370 kg)	#1: 728 lbs (330kg) #2: 276 lbs (125kg)	85

*Warranty must be registered. Improper electrical connection voids warranty. Ensure supplied power matches specification on nameplate

**Weights are approximate and assume AR of 60% for typical bread dough, adjust load accordingly, overloading voids warranty

***Measurement after full assembly and with trays stored, extending the dough catch trays will add approximately 10-12" length on each side

****Crates are affixed to a skid (pallet). The weight and dimensions of this skid are included and may vary from shipment to shipment.



Quality • Value • Reliability